

- Seat valve, direct-acting
- Wide range of applications
- Port connection size up to G 1/2
- Brass or stainless steel valve body

Type 0256 can be combined with...

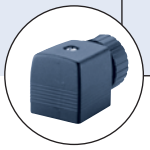

**Type 2508**

Cable plug



**Type 1078**

Timer unit



**Type 2511**

ASI cable plug

This direct-acting plunger solenoid valve Type 0256 can be used in many ways. It is delivered with brass or stainless steel bodies for a wide range of orifices and connections.

#### Circuit function A

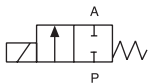

2/2-way valve, normally closed by spring force

Technical data	
<b>Orifice</b>	DN 3.0 - 12.0 mm
<b>Body material</b>	Brass (Body C with stainless steel seat 1.4112) or stainless steel 1.4581
<b>Seal material</b>	NBR, FKM, EPDM, steel on request
<b>Media</b>	NBR FKM All materials
<b>Media temperature</b>	NBR (EPDM on request) FKM
	-10 to +80 °C -10 to +130 °C
<b>Ambient temperature</b>	Max. +55°C
<b>Viscosity</b>	Max. 21 mm <sup>2</sup> /s
<b>Voltage tolerance</b>	± 10%
<b>Duty cycle</b>	100% continuous rating
<b>Electrical connection</b>	Cable plug for Ø 7 mm cable (supplied as standard) *
<b>Protection class</b>	IP 65 with cable plug
<b>Installation</b>	As required, preferably with actuator upright
<b>Flow rate</b>	measured at +20°C, 1 bar pressure at valve inlet and free outlet
Kv value water [m <sup>3</sup> /h]	
<b>Pressure valves [bar]</b>	gauge pressures with respect to the prevailing atmosphere pressure
<b>Response times [ms]</b>	measured with water at valve outlet at 6 bar and +20°C
Opening	pressure build-up 0 to 90%
Closing	pressure decay 100 to 10%

\* cable plug Type 2508 (supplied as standard) acc. to DIN EN 175 301-803, Form A

## Technical data

Orifice [mm]	Power consumption			Response times				Weight
	Inrush	Hold		Opening		Closing		
	AC [VA]	AC [VA/W]	DC [W]	AC [ms]	DC	AC [ms]	DC	
3 to 12	35-40	16/10	approx. 12	10-20	20-80	20-30	20-30	0.6

## Ordering chart for valves (other versions on request)

Valves A, B, C with brass body, DN 3.0 to 12.0 mm, with cable plug, without mounting bracket (see Accessories)  
Body C with stainless steel seat 1.4112

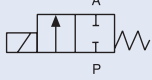
Circuit function	Orifice [mm]	Port connection [D]	Kv value water [m <sup>3</sup> /h]	Pressure range for gases [bar]	Pressure range for liquids [bar]	Body version (please see drawing)	Seal material	Voltage/frequency [V/Hz]	Item no.		
 2/2-way valve NC	3.0	G 1/4	0.25	0 - 10	0 - 10	C	NBR	024/DC	145 725		
				0 - 22	0 - 22	C	NBR	230/50	145 803		
	4.0	G 1/4	0.5	0 - 6	0 - 6	C	NBR	024/DC	145 727		
				0 - 16	0 - 12	C	NBR	024/50	145 728		
								110/50	145 730		
				0 - 13	0 - 10	C	NBR	230/50-60	121 566		
				0 - 16	0 - 12	C	NBR	230/50	145 731		
				G 3/8	0.5	0 - 6	0 - 6	C	FKM	024/DC	145 739
						0 - 16	0 - 12	C	FKM	230/50	145 740
						0 - 6	0 - 6	C	NBR	024/DC	145 733
	0 - 16	0 - 12	C			NBR	024/50	145 734			
				0 - 16	0 - 12	C	NBR	110/50	145 735		
					0 - 12	C	NBR	230/50	145 736		
	5.0	G 1/4	0.65	0 - 2.5	0 - 2.5	C	NBR	024/DC	145 747		
				0 - 12	0 - 6	C	NBR	024/50	145 748		
								110/50	145 749		
								230/50	145 750		
				G 3/8	0.65	0 - 2.5	0 - 2.5	C	NBR	024/DC	145 752
						0 - 12	0 - 6	C	NBR	024/50	145 753
							110/50	145 754			
							230/50	145 755			
	6.0	G 1/4	0.8	0 - 2	0 - 2	B	NBR	024/DC	145 760		
				0 - 8	0 - 4	B		230/50	145 763		
						C	FKM	024/50	145 774		
							NBR	024/50	145 761		
				0 - 2	0 - 2	C		024/DC	145 759		
						C		110/50	145 762		
						C		230/50	145 764		
G 3/8				8.0	0 - 8	0 - 4	C	FKM	024/50	145 775	
							B	FKM	230/50	145 804	
					0 - 2	0 - 2	C	NBR	024/DC	145 766	
					0 - 8	0 - 4	C	NBR	024/50	145 767	
									110/50	145 768	
						230/50	145 769				

Note: The pressure values for liquids are shown on the rating plates! For mounting brackets, please refer to the accessories for Type 0256.

Ordering chart for valves (other versions on requests)

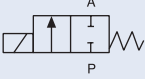
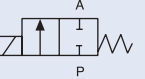
Circuit function	Orifice [mm]	Port connection [D]	Kv value water [m <sup>3</sup> /h]	Pressure range for gases [bar]	Pressure range for liquids [bar]	Body (please see drawing)	Seal material	Voltage/frequency [V/Hz]	Item no. EPDM diaphragm material
 2/2-way valve NC	6.0	G 1/2	0.8	0-2	0-2	A	FKM	024/DC	145 776
							NBR	024/DC	145 771
								230/50	145 772
	8.0	G 3/8	0.9	0-0.5	0-0.5	C	NBR	024/DC	145 778
								024/50	145 779
								110/50	145 780
								230/50	145 781
	10	G 1/2	1.5	0 - 0.4	0 - 0.4	A	FKM	024/DC	145 806
								024/50	145 792
								024/DC	145 788
								024/50	145 789
								110/50	145 790
								230/50	120 133
	12.0	G 1/2	1.8	0 - 1	0 - 0.5	A	FKM	230/50	145 801
								024/DC	145 796
024/50								145 797	
110/50								145 798	
230/50								145 799	
All valves with stainless steel body A und B; DN 4, 10 and 12; 1.4581, with cable plug, without mounting bracket (see Accessories)									
 A 2/2-way valve NC	4.0	G 1/4	0.5	0 - 6	0 - 6	B	FKM	024/DC	145 742
	10.0	G 1/2	1.5	0 - 1.5	0 - 1	A	FKM	024/50	145 793
	12.0	G 1/2	1.8	0 - 1	0 - 0.5	A	FKM	230/50	145 802

Note: valves with high-power electronic for increased pressures on request

Dimensions [mm]

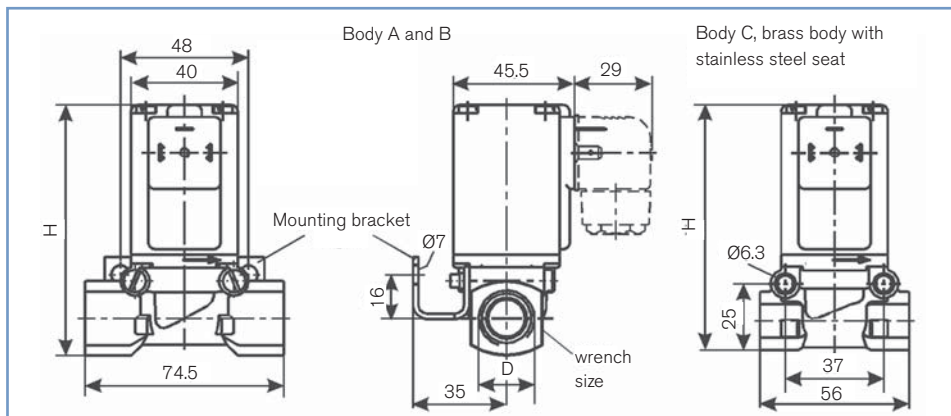

Body	Body material	Connection D	H [mm]	wrench size [mm]
A	Brass, stainless steel body without bore hole mounting	G 1/2	95.5	27
B	Brass body with bore hole mounting	G 1/4, G 3/8	91	22
B	Stainless steel body without bore hole mounting	G 1/4	92	22
C	Brass body with bore hole mounting	G 1/4, G 3/8	92	22

Materials

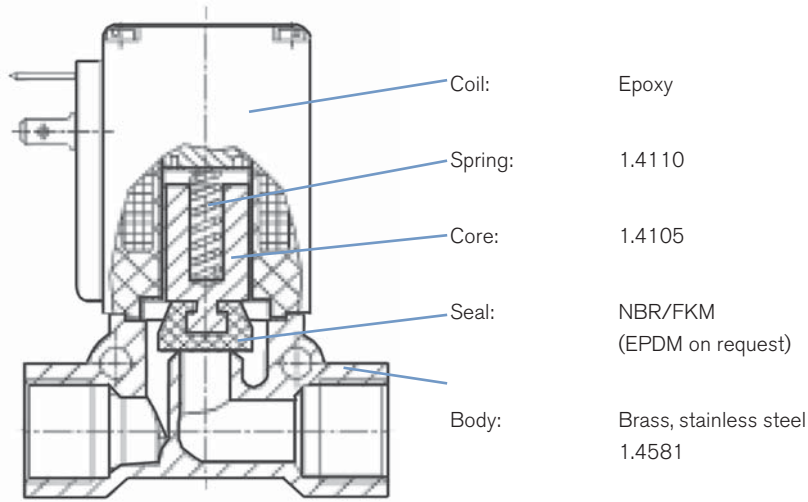

**Mounting set** (only for brass body)

- 2 M6 x 35 cheesehead screws
- 1 mounting bracket

Valve mounted using mounting kit  
Refer to the dimensional drawings for the valve

37 mm separation between the M6 threaded holes  
48 mm separation between the Ø7 bores

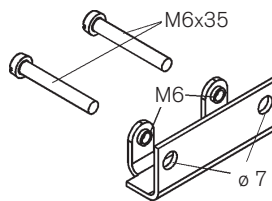

Item no. 151 287

To find your nearest Bürkert facility, click on the orange box → [www.burkert.com](http://www.burkert.com)

In case of special application conditions,  
please consult for advice.

We reserve the right to make technical  
changes without notice

0606/2\_EN-en\_00891615