

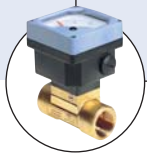

2/2-way Angle Seat Valve, manually operated, for media up to +180 °C

- Position indication
- Adjustable flow rates
- Stainless steel valve body
- Compact industrial design with long service life
- Excellent seat tightness due to PTFE soft sealing

Type 2000/2702 can be combined with...



Type 8034
Flow Indicator



Type 8035
Flow Transmitter



Type 8311
Pressure Transmitter
with display



Type 8314
Pressure Transmitter



Type 8400
Temperature Transmitter
with display

Manually-operated angle-seat valve of the type series 2000/2702 are delivered as standard with threaded or weld end port connection. Type 2000 with manual actuator without position indicator is used only for On/Off function. Type 2702 with manual actuator and position indicator is designed with a parabolic trim and therefore it can be used to control a defined flow.

Technical data	Flow direction below the seat (for gases and fluids)
Port size	DN15-50
Body material Type 2000 weldend acc. to EN ISO 1127/150 4200 & DIN 11850 S2	Stainless steel 316L Stainless steel 1.4581
Actuator material	PPS
Seal material (Type 2000)	PTFE
Seal material (Type 2702)	PTFE or stainless steel 1.4571
Medium	Neutral gases, water, alcohols, oils, fuels, salt solutions, lye, organic solvents, steam
Viscosity	Max. 600 mm ² /s
Packing gland	PTFE V-rings (silicone grease)
Nominal pressure	PN 16 (DN 15-25) PN 10 (DN 32-50)
Temperatures Fluid Ambient	-10 to +180 °C (max. +130 °C for PTFE/St.st. Sealing recommended -10 to +60 °C
Flow direction Type 2000 Type 2702	any flow direction below seat
Installation	As required
Port connections Type 2000/2702 Optional	G threaded port, weld end acc. EN ISO 1127/ISO 4200, weld end acc. DIN 11850 series 2 NPT, Rc threaded port, Weld end acc. BS 4825, ASME, SMS 3008
Options	Handwheel with locking against unauthorised or unintentional changing of the valve position

Materials - Flow rates

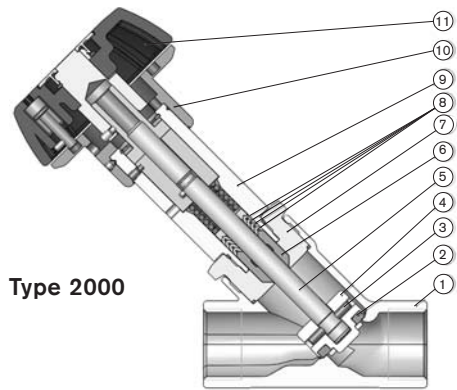

Type 2000

Type 2000

- 1 Valve body: 316 L
Weld end acc. to EN ISO 1127/150 4200 & DIN 11850 S2 1.4581
- 2 Seal: PTFE
- 3 Pin: 1.4404
- 4 Swivel plate: 1.4404
- 5 Spindle: 1.4404
- 6 Wiper: PTFE
- 7 Nipple: 1.4404
- 8 V-Seals: PTFE
- 9 Tube: 1.4404
- 10 Torque support: PPS
- 11 Manual actuator: PPS
(without position indicator)

Kv-value

DN	Kvs [m³/h]
13/15	4.5
20	10
25	20
32	28
40	42
50	55

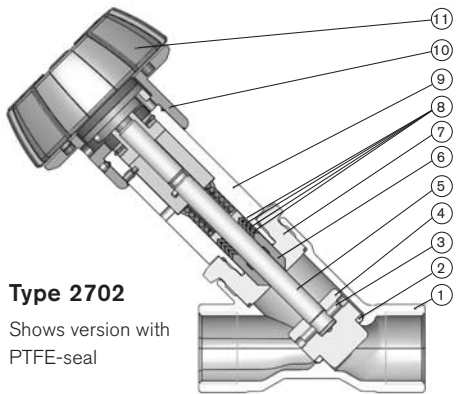

Type 2702

Shows version with PTFE-seal

Type 2702

- 1 Valve body: 316 L
- 2 Seal: PTFE (not applicable for 316 L seat sealing version)
- 3 Pin: 1.4310
- 4 Parabolic trim: 1.4571
- 5 Spindle: 1.4404
- 6 Wiper: PTFE
- 7 Nipple: 1.4404
- 8 V-Seals: PTFE
- 9 Tube: 1.4404
- 10 Torque support: PPS
- 11 Manual actuator: PPS
(with position indicator)

Kvs-value

DN	Kvs [m³/h]	Min.Stroke [mm]
13/15	4.5	12
20	9	18
25	15	20
32	23	20
40	33	24
50	52	26

Kv-values 2702

Port size [mm]		Stroke [%]											
		5	10	20	30	40	50	60	70	80	90	100	
13/15	Stroke [mm]	0.6	1.2	2.4	3.6	4.8	6.0	7.2	8.4	9.6	10.8	12.0	
	Kv [m³/h]	0.23	0.24	0.26	0.35	0.7	1.85	2.9	3.5	4	4.3	4.5	
20	Stroke [mm]	0.9	1.8	3.6	5.4	7.2	9.0	10.8	12.6	14.4	16.2	18.0	
	Kv [m³/h]	0.3	0.33	0.42	0.7	2.85	5.3	6.6	7.5	8.2	8.6	9	
25	Stroke [mm]	1.0	2.0	4.0	6.0	8.0	10.0	12.0	14.0	16.0	18.0	20.0	
	Kv [m³/h]	0.39	0.41	0.60	1.25	4.5	8.5	10.5	12.2	13.5	14.2	15	
32	Stroke [mm]	1.0	2.0	4.0	6.0	8.0	10.0	12.0	14.0	16.0	18.0	20.0	
	Kv [m³/h]	0.55	0.65	0.95	1.5	4	9.3	13.8	16.5	18.8	21	23	
40	Stroke [mm]	1.3	2.0	5.2	7.8	10.4	13	15.6	18.2	20.8	23.4	24	
	Kv [m³/h]	0.65	0.85	1.5	5	14	20	25	27	30	32.5	33	
50	Stroke [mm]	1.3	2.6	5.2	7.8	10.4	13	15.6	18.2	20.8	23.4	26	
	Kv [m³/h]	1	1.3	2	5	16	27	34	41	45	49	53	

Indication

The value of the position indication is a distance in [mm], in general the actual stroke (distance between valve-seat and seat-seal in mm).



The digit after the vertical line represents 1/10 mm. Per revolution of the handwheel, the vertical position of the valve will change exactly 1.5 mm. For tuning of a well-defined flow rate, please take the chart with the flow rate and the stroke.

Flow characteristics

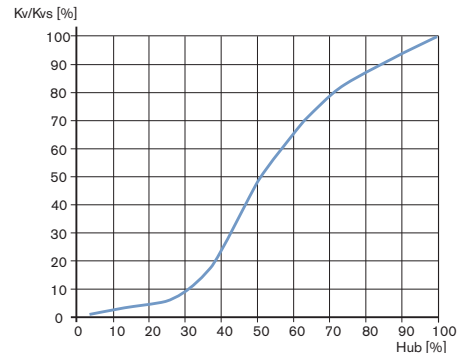

Ordering chart for valves (other versions on request)

**Type 2000**

Seat sealing PTFE

Any flow direction

Port Size		Kvs value water [m ³ /h]	Max. operating pressure [bar]	Seal material	Weight [kg]	Item no.
[mm]	[inch]					
Type 2000 body with G threaded port (without position indicator)						
13	1/2"	4.5	0-16	PTFE	1.2	219 720
20	3/4"	10	0-16	PTFE	1.25	219 721
25	1"	20	0-16	PTFE	1.58	219 722
32	1 1/4"	28	0-10	PTFE	2.13	219 723
40	1 1/2"	42	0-10	PTFE	2.5	219 724
50	2"	55	0-10	PTFE	3.72	166 080
Type 2000 body with weld end acc. EN ISO 1127/ISO 4200 (without position indicator)						
15	1/2"	4.5	0-16	PTFE	1.2	166 016
20	3/4"	10	0-16	PTFE	1.25	166 019
25	1"	20	0-16	PTFE	1.58	166 072
32	1 1/4"	28	0-10	PTFE	2.13	166 075
40	1 1/2"	42	0-10	PTFE	2.5	166 078
50	2"	55	0-10	PTFE	3.72	166 081
Type 2000 body with weld end acc. DIN 11850 series 2 (without position indicator)						
15	1/2"	4.5	0-16	PTFE	1.2	166 017
20	3/4"	10	0-16	PTFE	1.25	166 020
25	1"	20	0-16	PTFE	1.58	166 073
32	1 1/4"	28	0-10	PTFE	2.13	166 076
40	1 1/2"	42	0-10	PTFE	2.5	166 079
50	2"	55	0-10	PTFE	3.72	166 082

**Type 2702**

Seat sealing PTFE, parabolic plug

Flow direction below seat

Port Size		Kvs value water [m ³ /h]	Max. operating pressure [bar]	Seal material	Weight [kg]	Item no.
[mm]	[inch]					
Type 2702 body with G threaded port (with position indicator)						
13	1/2"	4.5	0-16	PTFE	1.2	219 725
20	3/4"	9.0	0-16	PTFE	1.25	219 727
25	1"	15	0-16	PTFE	1.58	219 729
32	1 1/4"	23	0-10	PTFE	2.13	219 731
40	1 1/2"	33	0-10	PTFE	2.5	219 733
50	2"	53	0-10	PTFE	3.72	166 111
Type 2702 body with weld end acc. EN ISO 1127/ISO 4200 (with position indicator)						
15	1/2"	4.5	0-16	PTFE	1.2	166 097
20	3/4"	9.0	0-16	PTFE	1.25	166 100
25	1"	15	0-16	PTFE	1.58	166 103
32	1 1/4"	23	0-10	PTFE	2.13	166 106
40	1 1/2"	33	0-10	PTFE	2.5	166 109
50	2"	53	0-10	PTFE	3.72	166 112
Type 2702 body with weld end acc. DIN 11850 series 2 (with position indicator)						
15	1/2"	4.5	0-16	PTFE	1.2	166 098
20	3/4"	9.0	0-16	PTFE	1.25	166 101
25	1"	15	0-16	PTFE	1.58	166 104
32	1 1/4"	23	0-10	PTFE	2.13	166 107
40	1 1/2"	33	0-10	PTFE	2.5	166 110
50	2"	53	0-10	PTFE	3.72	166 113

Ordering chart for valves (other versions on request)



Type 2702
 Seat sealing
 stainless steel
 parabolic plug

Flow direction
 below seat

Port Size		Kvs value water [m³/h]	Max. operating pressure [bar]	Seal material (parabolic trim)	Weight [kg]	Item no.
[mm]	[inch]					
Type 2702 body with G threaded port (with position indicator)						
13	1/2"	4.5	0-16	1.4571	1.2	219 726
20	3/4"	9.0	0-16	1.4571	1.3	219 728
25	1"	15	0-16	1.4571	1.6	219 730
32	1 1/4"	23	0-10	1.4571	2.1	219 732
40	1 1/2"	33	0-10	1.4571	2.5	219 734
50	2"	53	0-10	1.4571	3.7	166 129
Type 2702 body with weld end acc. EN ISO 1127/ISO 4200 (with position indicator)						
15	1/2"	4.5	0-16	1.4571	1.2	166 115
20	3/4"	9.0	0-16	1.4571	1.3	166 118
25	1"	15	0-16	1.4571	1.6	166 121
32	1 1/4"	23	0-10	1.4571	2.1	166 124
40	1 1/2"	33	0-10	1.4571	2.5	166 127
50	2"	53	0-10	1.4571	3.7	166 130
Type 2702 body with weld end acc. DIN 11850 series 2 (with position indicator)						
15	1/2"	4.5	0-16	1.4571	1.2	166 116
20	3/4"	9.0	0-16	1.4571	1.3	166 119
25	1"	15	0-16	1.4571	1.6	166 122
32	1 1/4"	23	0-10	1.4571	2.1	166 125
40	1 1/2"	33	0-10	1.4571	2.5	166 128
50	2"	53	0-10	1.4571	3.7	166 131

The manual actuator of Type 2000 and 2702 can also be combined with different globe valve bodies (on request)

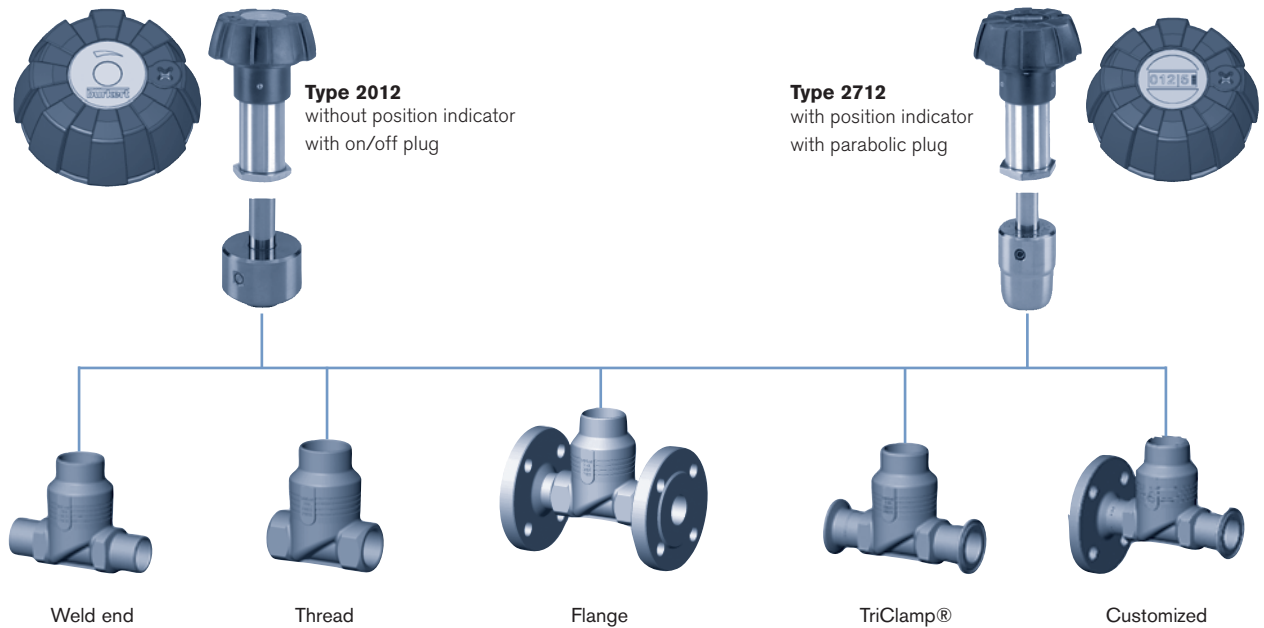

Dimensions [mm]

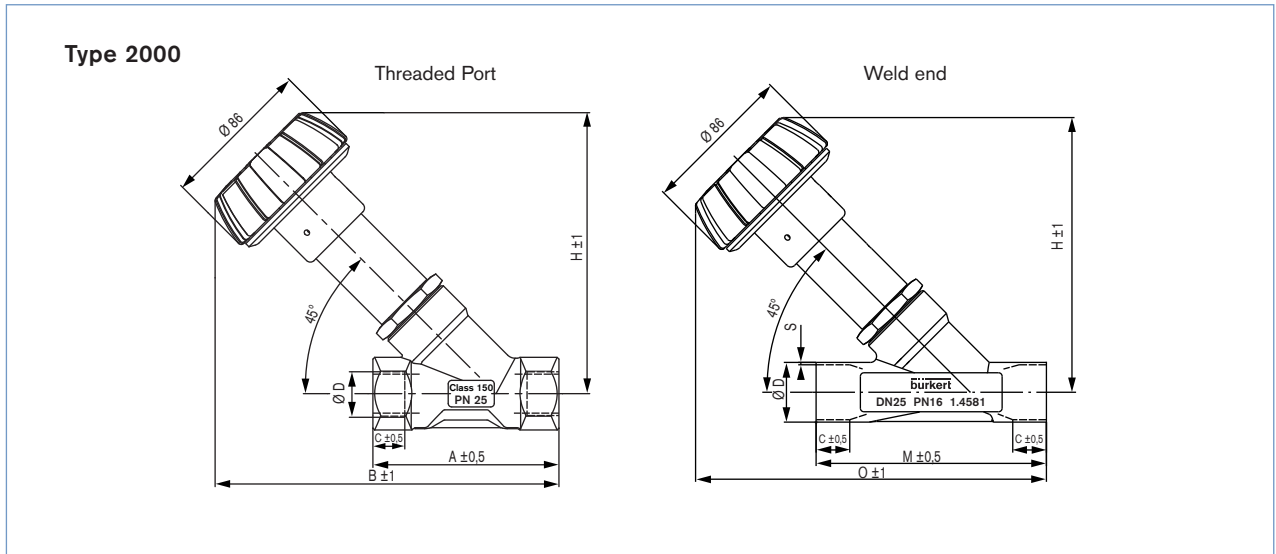

All bodies orifice [mm]	All threaded ports			G thread		NPT thread		Rc thread		All weld end bodies			EN ISO 1127/ISO 4200			DIN 11850 S2		
	A	B	H	ØD	C	ØD	C	ØD	C	M	O	H	ØD	S	C	ØD	S	C
15	65	178	153.6	G 1/2	14	NPT 1/2	13.7	Rc 1/2	13.2	100	186.2	152.2	21.3	1.6	5	19	1.5	6
20	75	180	152.9	G 3/4	16	NPT 3/4	14.0	Rc 3/4	14.5	115	190.5	151.5	26.9	1.6	5	23	1.5	6
25	90	188	158.8	G 1	18	NPT 1	16.8	Rc 1	16.8	130	198.0	155.0	33.7	2	8	29	1.5	10
32	110	201	165.0	G 1 1/4	20	NPT 1 1/4	17.3	Rc 1 1/4	19.1	145	210.0	165	42.4	2	8	35	1.5	6
40	120	211	175.6	G 1 1/2	22	NPT 1 1/2	17.3	Rc 1 1/2	19.1	160	218.2	169.2	48.3	2	8	41	1.5	10
50	150	239.1	194.1	G 2	24	NPT 2	17.6	Rc 2	23.4	175	235.6	185.6	60.3	2.6	12	53	1.5	10

Other valve bodies on request

Dimensions [mm]

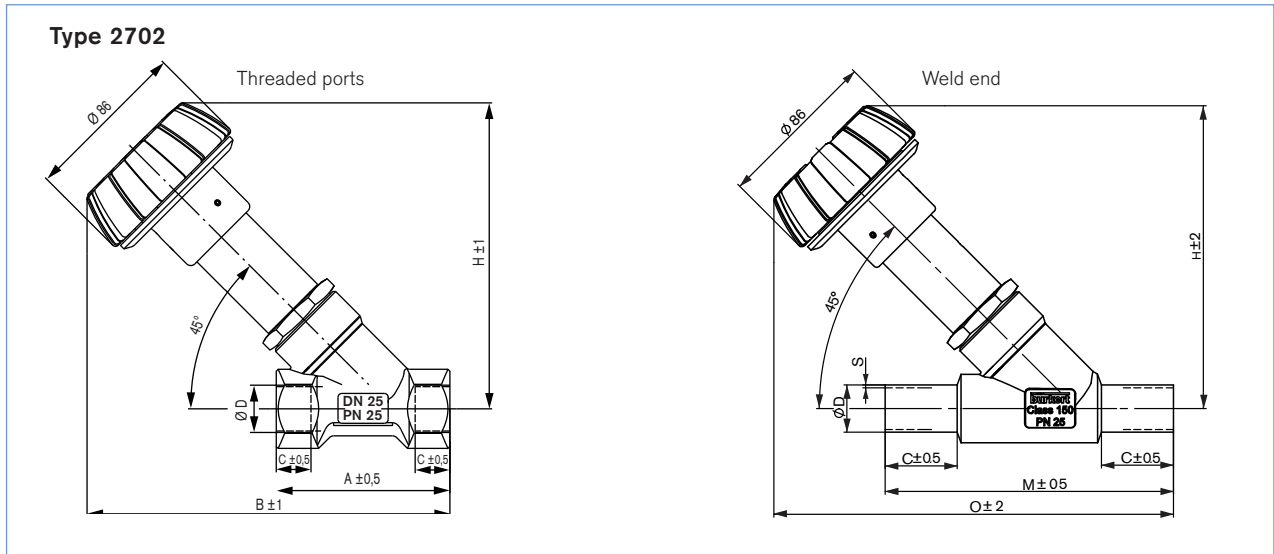

All bodies orifice [mm]	All threaded ports			G thread		NPT thread		Rc thread	
	A	B	H	$\varnothing D$	C	$\varnothing D$	C	$\varnothing D$	C
15	65	178	154	G 1/2	14	NPT 1/2	13.7	Rc 1/2	13.2
20	75	180	153	G 3/4	16	NPT 3/4	14.0	Rc 3/4	14.5
25	90	188	159	G 1	18	NPT 1	16.8	Rc 1	16.8
32	110	201	165	G 1 1/4	20	NPT 1 1/4	17.3	Rc 1 1/4	19.1
40	120	211	176	G 1 1/2	22	NPT 1 1/2	17.3	Rc 1 1/2	19.1
50	150	239.5	194.5	G 2	24	NPT 2	17.6	Rc 2	23.4

All bodies orifices [mm]	EN ISO 1127/ISO 4200 and DIN 11850 R2									BS 4825 Part 1, ASME, SMS 3008									
				EN ISO 1127/ISO 4200			DIN 11850 S2			BS 4825 Part 1				ASME		SMS 3008			
	M	O	H	$\varnothing D$	S	C	$\varnothing D$	S	C	M	O	H	C	$\varnothing D$	S	$\varnothing D$	S	$\varnothing D$	S
15	100	192.5	158.5	21.3	1.6	20	19	1.5	20	135	204.5	158.5	38	12.7	1.2	12.7	1.65	12	1
20	115	197.0	158	26.9	1.6	25	23	1.5	20	145	210	158	38	19.05	1.2	19.05	1.65	18	1
25	130	202.2	159.5	33.7	2	30	29	1.5	26	152	210.5	159.5	38	25.4	1.65	25.4	1.65	25	1.2
32	145	210.0	170	42.4	2	26	35	1.5	26	-	-	-	-	-	-	-	-	-	-
40	160	223.0	173	48.3	2	30	41	1.5	26	182	233	173	38	38.1	1.65	38.1	1.65	38	1.2
50	175	240.5	190.5	60.3	2.6	35	53	1.5	38	210	254.5	190.5	45	50.8	1.65	50.8	1.65	51	1.2

Other valve bodies on request

To find your nearest Burkert facility, click on the orange box →

www.burkert.com

In case of special application conditions, please consult for advice

Subject to alterations
© Christian Bürkert GmbH & Co. KG

1111/3_EU-en_00891654