

Mass Flow Meter (MFM) for Gases



- Inline MFM for nominal flow rates from 25 l_N/min to 1,500 l_N/min; 1/4" to 3/4"
- High accuracy
- Fast response time
- Fieldbus option

Type 8006 can be combined with...



Type 1150

Multi-channel program controller



Type 0330

3/2 or 2/2-way solenoid valve



Type 6013

2/2-way solenoid valve



MFC

Communications Software

Mass flow meters are used in process technology for the direct measurement of the mass flow of gases. In case of volumetric flow meters, it is necessary to measure the temperature and the pressure either the density, because gases change their density or rather their volume depending on the pressure. The measurement of the mass flow, on the other hand, is independent of the pressure and the temperature. The digital mass flow meter Type 8006 uses an inline sensor based on the thermal principle (see the description on page 2) located directly in the main channel. Due to the fact that the sensor is directly in the main channel a very fast response time of the MFM is reached. Another benefit of this main stream measurement is that it is less sensitive to contamination. The actual flow is given as an analog output signal or could be read out over fieldbus communication. Type 8006 can optionally be calibrated for

two different gases, the user is able to switch between these two gases. The materials of the parts that come into contact with the medium are selected according to customer specification so that the unit can be operated with the complete range of standard process gases.

Typical application areas are gas flow measurements in:

- Heat treating processes
- Test benches
- Packaging
- Food and beverage processes
- Environmental technology

Technical data			
Full scale ranges ¹⁾ (Q _{nom})	25 to 1,500 l _N /min Reference medium N ₂	Power supply	24V DC
Operating media	Neutral, non-contaminated gases, others on request	Voltage tolerance	±10%
Max. operating pressure	Up to max. 10 bar	Residual ripple	< 2%
Max. pressure drop	120 mbar (with air and 6 barg inlet pressure)	Power consumption	Max. 10W Max. 12.5 W (Bus version)
Calibration medium	Operating gas or air with conversion function	Output signal (actual value output) Max. current, (voltage output) Max. load, (current output)	0–5 V, 0–10 V, 0–20 mA or 4–20 mA 10 mA 600 Ω
Medium temperature	-10 to +70°C	Fieldbus communication	PROFIBUS-DP, DeviceNet, CANopen
Ambient temperature	-10 to +45°C	Protection class	IP65
Accuracy (after 15 min. warm up time)	±1.5% of rate ±0.3% F.S.	Dimensions [mm]	See drawings on p. 4
Linearity	±0.25% F.S.	Total weight (Examples for standard blocks)	1.2 kg (Al) 3.0 kg (VA)
Repeatability	±0.1% F.S.	Mounting position	Horizontal or vertical ²⁾
Control range	1:50	Light emitting diodes (Default, other allocations possible)	Indication for power, communication, limit, error
Response time (t_{95%})	<500 ms	Binary input (Default, other functions possible)	Three, different functions possible – with default not assigned
Body material	Stainless steel or aluminium (anodised)	Binary output (Default, other functions possible)	Two relay outputs for 1. limit (Q _{nom} almost reached) 2. error (e.g. sensor fault) max. load 30VDC, 1A/30VAC, 0,5A
Electronics housing material	Aluminium (coated)		
Sealing material	FPM, EPDM (others on request)		
Port connection	G 1/4, 3/8, 1/2, 3/4, NPT 1/4, 3/8, 1/2, 3/4		
Elec. connection	Round socket 8-pin Sub-HD socket 15-pin Sub-D socket 9-pin (only for fieldbus)		

¹⁾ At reference conditions 1.013 bar(a) and 0°C

²⁾ With flow downwards limited span

Functional principle of the Sensor Element

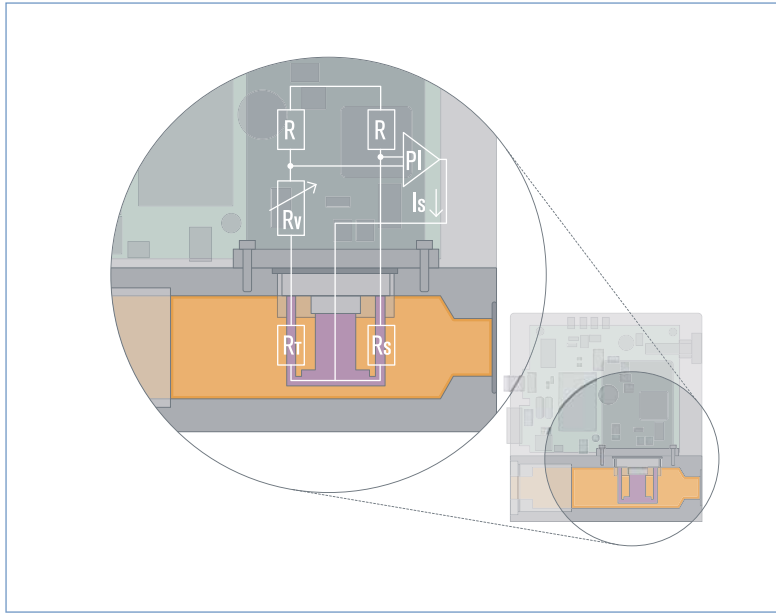

This sensor works as a hot-film anemometer in the so-called CTA operational mode (Constant Temperature Anemometer). To do this, two resistors with precisely specified temperature coefficients are located directly in the media flow and three resistors are located outside the flow are connected together to form a bridge.

The first resistor in the medium flow (R_T) measures the fluid temperature, the second, low-value resistor (R_S) is heated so that it is maintained at a

fixed, predefined over-temperature with respect to the fluid temperature. The heating current required to maintain this is a measure of the heat being removed by the flowing gas, and represents the primary measurement.

An adequate flow conditioning within the MFM and the calibration with high-quality flow standards ensure that the mass of gas flowing per time unit can be derived from the primary signal with high accuracy.

Notes regarding the selection of the unit

The decisive factors for the perfect functioning of an MFM within the application are the fluid compatibility, the normal inlet pressure and the correct choice of the flow meter range. The pressure drop over the MFM depends on the flow rate and the operating pressure.

- ▶ **The questionnaire on page 5 contains the relevant fluid specification. Please use in this way the experience of Burkert engineers already in the design phase and provide us with a copy of the questionnaire containing the data of your application together with your inquiry or order.**

Ordering table for accessories (connectors are not included in the delivery)

Article	Item no.
Round plug 8-pin Binder (solder connection)	918 299
Round plug 8-pin with 5m – cable, on one side prefabricated	787 733
Round plug 8-pin with 10m – cable, on one side prefabricated	787 734
SUB-HD-plug 15-pin with 5m – cable, on one side prefabricated	787 735
SUB-HD-plug 15-pin with 10m – cable, on one side prefabricated	787 736
RS232 adapter – for connection to a PC	654 757
Cable for RS232 adapter, 9-pin socket/plug 2m	917 039
RS485 adapter	658 499
USB adapter	670 696
Communications software (Mass Flow Communicator)	Info at www.buerkert.com

Pin Assignment

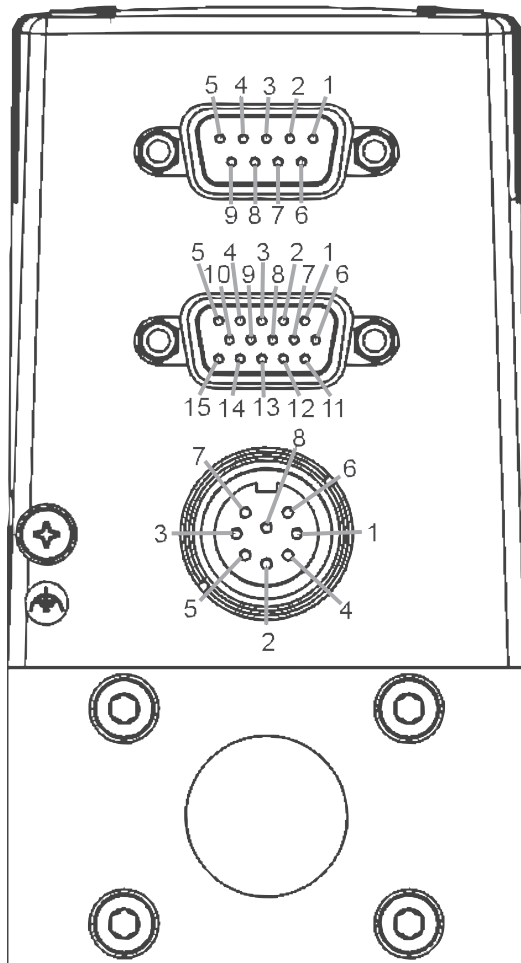

Sub-D socket 9-pin

with PROFIBUS-DP

Pin	Connection
1	shield
2	not used
3	RxD/TxD - P (B-line)
4	RTS (control signal for repeater)
5	GND
6	VDD
7	not used
8	RxD/TxD - N (A-line)
9	not used

with DeviceNet, CANopen

Pin	Connection
1	shield
2	CAN_L
3	GND
4	not used
5	not used
6	not used
7	CAN_H
8	not used
9	not used

Sub-HD socket 15-pin

Pin	Connection
1	not used
2	not used
3	signal output +
4	binary input 2
5	12V-output (only company internal use)
6	RS232 TxD (direct connection to PC)
7	binary input 1
8	DGND (for binary inputs)
9	only company internal use (do not connect!)
10	12V-output (only company internal use)
11	12V-output (only company internal use)
12	binary input 3
13	signal output GND
14	RS232 RxD (direct connection to PC)
15	DGND (for RS232)

(with bus version 3 and 13 not used)

Socket round 8-pin

Pin	Connection
1	supply 24V +
2	relay 1 - middle contact
3	relay 2 - middle contact
4	relay 1 - opener
5	relay 1 - closer
6	supply GND
7	relay 2 - closer
8	relay 2 - opener

Dimensions [mm]

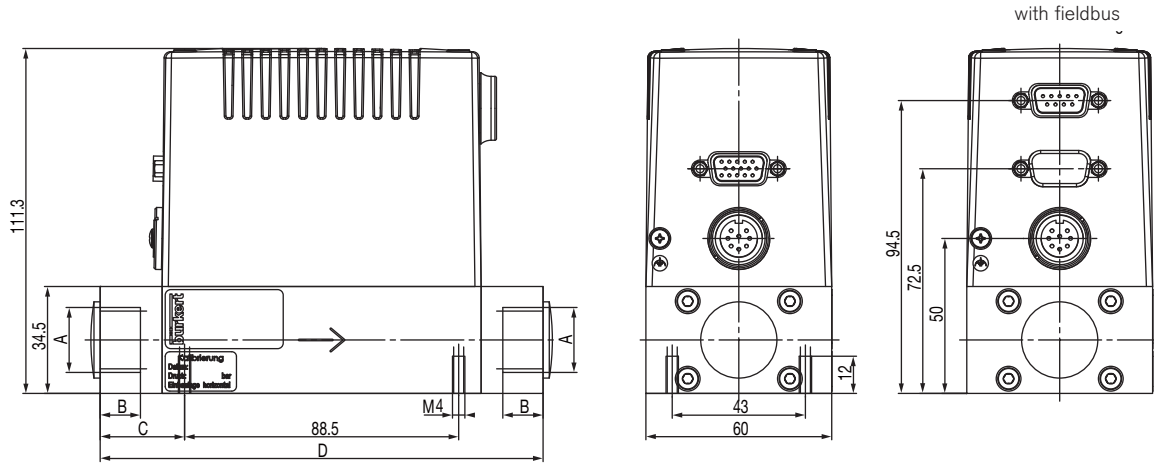

A	B	C	D
G 3/4; NPT 3/4	14	27.25	143
G 1/2; NPT 1/2	13	27.25	143
G 3/8; NPT 3/8	10	22.25	133
G 1/4; NPT 1/4	10	22.25	133

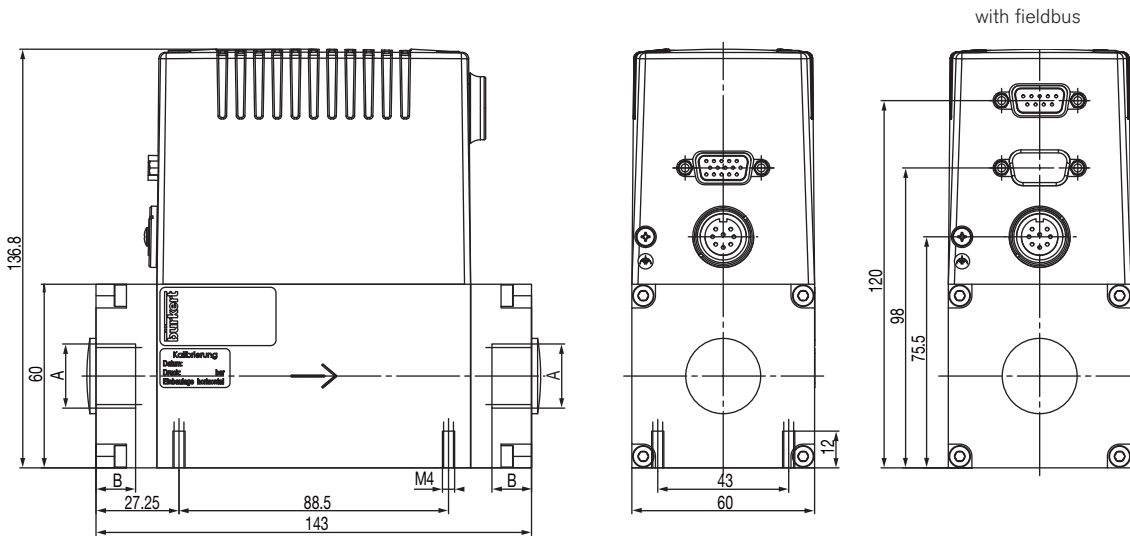

A	B
G 3/4; NPT 3/4	15
G 1/2; NPT 1/2	13

