

LFC Liquid Flow Controller



- High dynamic control through fast flow measurement
- Applicable for liquid dosing up to 600 ml/min (36 l/h)
- No moving parts in medium
- Fieldbus optional
- Compact version

Type 8718 can be combined with...



Type 1150

Multi-channel
program controller



Type 6606

2/2-way
Solenoid Valve



Type 6011

2/2-way
Solenoid Valve



MassFlowCommunicator

Communications
Software

Type 8718 is an instrument for liquid flow control in process technology.

The measured value provided by the sensor will be compared in the digital control electronics with the predefined set point according to the signal; if a control difference is present, the control value output to the proportional valve will be modified using a PI-control algorithm.

In this way, the flow can be maintained at a fixed value or a predefined profile can be followed, regardless of pressure variations or other changes in the system.

As a control element, a proportional valve working at low friction guarantees a high sensitivity and the good control characteristics of the unit.

Typical application areas of liquid dosing are:

- Heat treatment
- Machine tools
- Fuel cell technology
- Packaging technology,
- Material coating,
- Bio reactors.

The device offers a particularly compact solution.

Technical data			
Full scale range (Q_{nom})	0.6 to 36 l/h (10 to 600 ml/min) re. water	Input signal (set point)	0-5 V, 0-10 V, 0-20 mA or 4-20 mA
Operating medium	Clean and low viscous liquids	Input impedance	>20 kΩ (voltage), <300 Ω (current)
Viscosity	0.4 to 4 cSt	Output signal (actual value)	0-5 V, 0-10 V, 0-20 mA or 4-20 mA
Max. operating pressure (at inlet)	Measurement range : up to max. 10 barg; typical max. 2 barg	Max. current voltage output	10 mA
Calibration medium	Water (conversion to operating medium with correcting function)	Max. burden current output	600 Ω
Medium temperature	10 to + 40 °C	Alternative input and output signal	Digital with fieldbus: ▪ PROFIBUS DP V1 ▪ DeviceNet ▪ CANopen
Ambient temperature	0 to + 55 °C	Type of protection	IP40
Accuracy	±1.5 % o.R. ±0.5 % F.S.	Dimensions [mm]	Standard version: 107 x 115.5 x 28 (BxHxT) Sub-base version: 107 x 115.5 x 43 (BxHxT)
Repeatability	±0.5 % F.S.	Total weight	Approx. 1000 g
Turn-down ratio	1:10	Installation	Horizontal or vertical
Settling time (t_{95%})	< 500 ms	Light emitting diodes	Indication for: 1. Power 2. Communication (only in fieldbus version) Limit (only in analogue version) 3. Error
Body material	Stainless steel	Binary inputs	Two: 1. Start Autotune 2. Open valve (for purging)
Housing	PC (Polycarbonate)	Binary output	A relay output for: 1. Limit (desired value can not be achieved) Capacity: max. 25 V, 1 A, 25 VA
Sealing material	FKM, EPDM, FFKM		
Port connection	G 1/8, NPT 1/8, G 1/4, NPT 1/4, sub-base		
Control valve	Proportional valve; normally close; depending on flow range and pressure		
Electrical Connection	Sub-D 15-pin plug M12 (PROFIBUS) 5-pin socket M12 (DeviceNet, CANopen) 5-pin plug		
Operating voltage	24 V DC ± 10 %		
Residual ripple	< 2 %		
Power consumption	Max. 7.5 W (10 W with fieldbus version)		

Measurement principle

The sensor measures the flow by means of differential pressure. An orifice in the main channel causes pressure loss at liquid flow which is measured by the differential pressure sensor. The sensor feedbacks a precise and temperature compensated signal out of which the electronics calculates the corresponding flow.

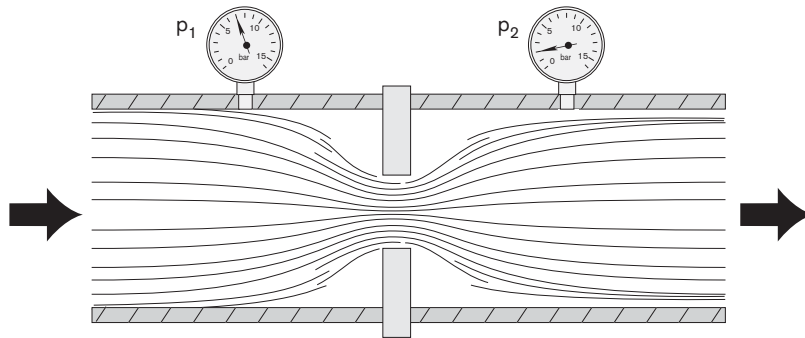

To avoid a blockage of the aperture by contaminated mediums an upstream filter is recommended.

Notes regarding the selection of the unit

For the proper choice of the actuator orifice and differential pressure sensor within the LFC, not only is the maximum flow rate Q_{nom} required, but also the pressure values directly before and after the LFC (p_1 , p_2) at this flow rate Q_{nom} should be known. In general, these pressures are not the same as the overall inlet and outlet pressures of the whole plant, because usually there are additional flow resistors (tubing, additional shut-off valves, nozzles etc.) present both before and after the controller. Please use the specification sheet (p. 5) to indicate the pressures directly before and after the LFC. If these should be unknown or not accessible to a measurement, estimates are to be made by taking into account the approximate pressure drops over the flow resistors before and after the LFC, respectively, at a flow rate of Q_{nom} .

In addition, please quote the maximum inlet pressure p_{1max} to be encountered. This data is needed to make sure the actuator is able to provide a close-tight function within all the specified modes of operation. The knowledge of the maximum inlet pressure is also necessary to select an adequate differential pressure sensor

- The request form on page 5 contains the relevant fluid specification. Please use the experience of Bürkert engineers already in the design phase and provide us with a copy of your request containing the necessary data together with your inquiry or order.

Ordering chart for accessories (Connectors are not included in the delivery)

Article	Item no.
15-pin Electrical Connection	
Sub-D 15-pin socket (solder connection)	918 274
Sub-D cover for Sub-D socket, with screw locking device	918 408
Sub-D 15-pin socket with prefabricated 5m cable on one side	787 737
Sub-D 15-pin socket with prefabricated 10m cable on one side	787 738
PROFIBUS DP	
M12 plug	918 198
M12 socket (coupling)	918 447
PROFIBUS Y-Connector	902 098
Adapter	
RS232 Adapter with extension cable to connect to PC (Item no. 917039)	654 748
RS485 Adapter	654 538
PC 2m extension cable for RS232, with 9-pin socket/plug	917 039
USB Adapter	670 639
Communications software, MassFlowCommunicator	Download at www.burkert.com

Pin Assignment

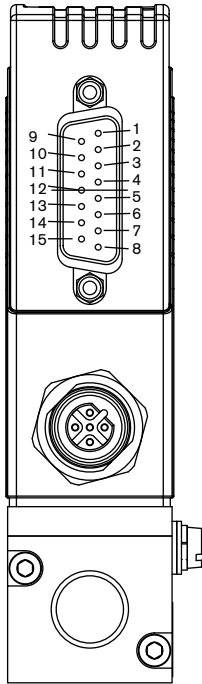

Sub-D 15-pin plug

Pin	Connection
1	Relay - NC contact
2	Relay - NO contact
3	Relay - middle contact
4	GND for 24V supply and binary inputs
5	24V Supply +
6	8V Output (only for internal company use)
7	Set value input GND
8	Set value input +
9	Actual value output GND
10	Actual value output +
11	DGND (for RS232)
12	Binary input 1
13	Binary input 2
14	RS232 RxD (without driver)
15	RS232 RxD (without driver)

Fieldbus version

PROFIBUS DP - M12 socket , B-coded
(DPV1 max. 12 Mbaud)

Pin	Connection
1	VDD
2	RxD/ TxD – N (A-circuit)
3	DGND
4	RxD/ TxD – P (B-circuit)
5	not configured

CANopen resp., DeviceNet - M12 Plug

Pin	Connection
1	Shield
2	not configured
3	DGND
4	CAN_H
5	CAN_L

